

A New Fault Injection Method for Liquid Rocket Pressurization and Feed Systems

Zhu Mingqing¹ Xie Gang¹ Shao Jintao² Chen Liping¹ Zhou Fanli²

¹CAD Centre, Huazhong University of Science and Technology, Wuhan, China, 430074

²Suzhou Tongyuan Software&Control Tech. Co., Suzhou, China, 215123
{zhumq,xieg,shaojt,chenlp,zhoufl}@tongyuan.cc

In the design of liquid rocket pressurization and feed systems, ground tests are the most widely used method for fault diagnoses. However, it is really hard or impossible to reappear some fault modes because of equipment restrictions, let alone covering all possible flight conditions. Fault simulation based on numerical method is an ideal way to overcome the shortage of ground tests. It relies on a detailed model of system behavior under nominal and faulty conditions (Daigle, 2011).

In this paper, we present a new fault injection method for liquid rocket pressurization and feed systems (PFS) without modifying the system structure. In particular, we develop a physics-based model of pressurization and feed systems based on Modelica, which describes both nominal and faulty behaviors in a unified way. To handle a large number of fault modes in PFS, we develop a configuration XML file containing all kinds of fault modes in a unified way. The XML file could be easily modified from GUI. In fact, the Modelica model and the fault mode are implicitly connected via the fault parameter, which lies in both the Modelica model and the fault mode. To realize the mapping between them, we introduce a mechanism that associates the Modelica model with specific fault modes based on customized Modelica annotation in MWorks®. The detailed process is given as below.

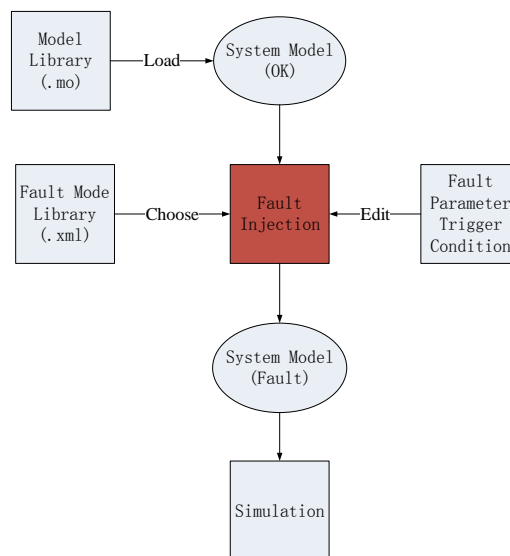

Figure 1 Fault Simulation Process

To prove the correctness of the system model and usefulness of the proposed method, we simulate several typical fault modes such as leakage and clogging and investigated their effects on the system performance.

References

Daigle M, Foygel M, Smelyanskiy V. Model-based diagnostics for propellant loading systems[C].Aerospace Conference, 2011 IEEE. pp. 1-11, 2011.