

Modelica Library for Feed Drive Systems

Denis Özdemir Tobias Motschke Werner Herfs Christian Brecher

Laboratory for Machine Tools and Production Engineering (WZL) of RWTH Aachen University,
Germany, {D.Oezdemir, T.Motschke, W.Herfs, C.Brecher}@wzl.rwth-aachen.de

As a part of machine tools and production machines, the primary task of feed drives is to create the contour of a workpiece by moving it and/or the tool along one or more axes according to the control input. At the engineering stage of a design process for feed drives the characteristic quantities are determined and affect the whole process of the product design. Simulation models can be used to predict system behavior in this stage of a development. However, their usability is limited if the models need parametrization with quantities that are not available at this stage of the development.

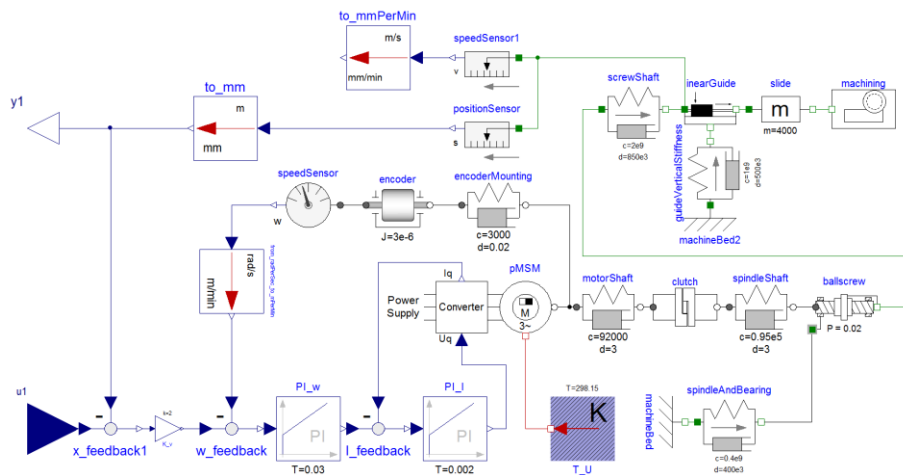

Figure 1: Model of the translational movement axis of a machine tool center

The paper presents several models regarding the topic of feed drives including rotational and translational systems. A special feature is the consideration of the insufficient availability of data during early development stages, which is contrary to the standard Modelica models. Therefore it helps solving the dilemma between less data and simulation quality. Considering manufacturer's catalogue data one is able to parametrize a model for the drive system and to make first investigations regarding the system behavior, including system dynamics or frequency domain analysis. The models are augmented with metrics to consider system restrictions that are naturally given in real systems. Examples for such restrictions are for instance maximum converter voltage for electrical drives, maximum temperatures or performance defining quantities. Beside the feed drive library, approaches for using the library in combination with databases and optimization tools are proposed at the end of the paper.